

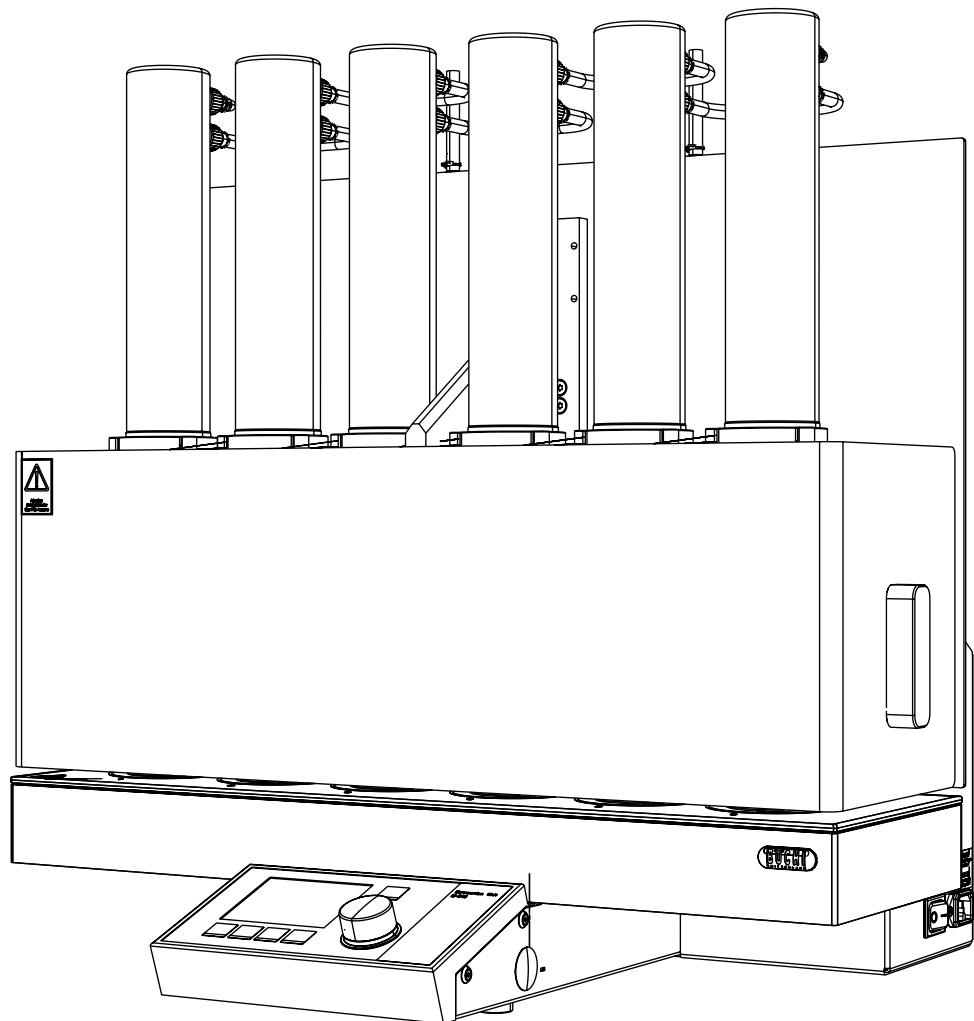

Extraction Units E-812 / E-816 SOX and HE

Technical data sheet

The declaration of the total fat or crude fat is required for most foods and feeds. The extraction units E-812 and E-816 SOX or HE were designed for an easy and fast fat determination. The E-812/816 SOX offers a truly automated Soxhlet extraction, which assures conformity in accordance with officially approved methods for total fat determination. For the fast determination of crude fat BUCHI provides the E-812/816 HE which performs the Hot Extraction (Randall) technique.



Scope of delivery

All models are delivered ready to use and are packaged with:

Components	E-812 SOX	E-812 HE	E-816 SOX	E-816 HE
Soxhlet glass chamber	2		6	
Beaker Soxhlet	2		6	
Beaker Hot Extraction		2		6
Holder for 6 beakers			1	1
Glass sample tubes	2	2	6	6
Holders for glass sample tubes	6	6	6	6
Z-seal, Viton	2	2	6	6
Paper thimbles 25 x 100 mm	12	12	12	12
Paper thimbles 33 x 94 mm	12	12	12	12
Holders for paper thimbles 25 x 100	6	6	6	6
Holders for paper thimbles 33 x 94	6	6	6	6
Box of boiling stones, 10 g	1	1	1	1
Pliers for glass sample tubes	1	1	1	1
Pliers for beakers	1	1	1	1
Cooling water hose, 1.5 m	1	1	1	1
Solvent hose, Tygon, 1 m	1	1	1	1
Solvent hose, PTFE, 0.5 m	1	1	1	1
Magnetic valve for Soxhlet	2		6	

Order code

Choose the configuration according to your needs:

0 4 9 1 [] []

2 place system: Extraction method

- 0 E-812 Hot Extraction, 100-120 V / 220-240 V 50/60 Hz
- 1 E-812 Soxhlet, 100-120 V / 220-240 V 50/60 Hz

0 4 7 5 8 []

6 place system: Extraction method

- 0 E-812 Hot Extraction, 100-120 V / 220-240 V 50/60 Hz
- 1 E-812 Soxhlet, 100-120 V / 220-240 V 50/60 Hz

Dimensions and weight

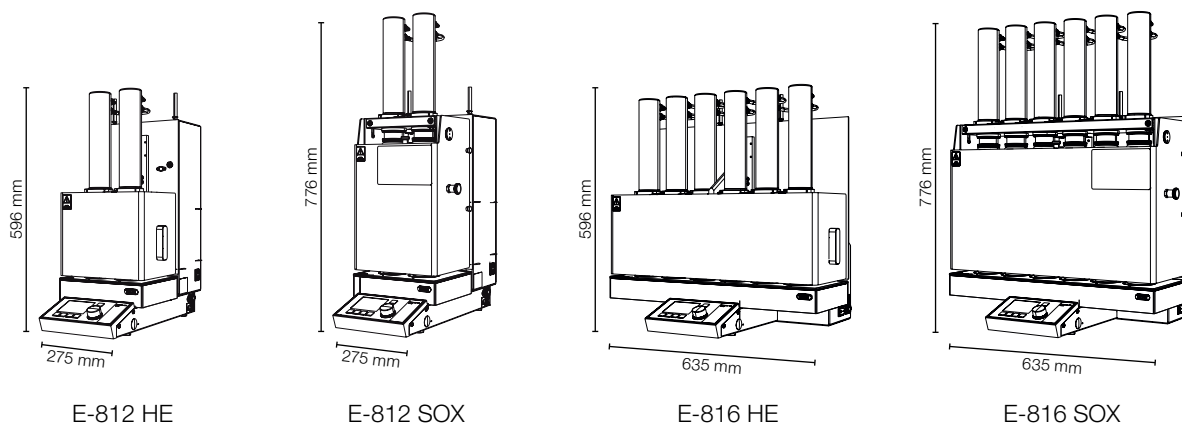

	Dimensions (WxHxD)	Weight
E-812 HE	275 x 596 x 456 mm	18 kg
E-812 SOX	275 x 776 x 456 mm	21 kg
E-816 HE	635 x 596 x 456 mm	30 kg
E-816 SOX	635 x 776 x 456 mm	36 kg









Technical data









	E-812 HE	E-812 SOX	E-816 HE	E-816 SOX
Beaker volume	260 mL	130 mL	260 mL	130 mL
Volume of glass sample tube	115 mL	115 mL	115 mL	115 mL
Volume of Soxhlet glass chamber	-	190 mL	-	190 mL
Max. cooling water consumption	72 L/h	72 L/h	72 L/h	72 L/h
Max. water pressure	4 bar	4 bar	4 bar	4 bar
Frequency	50/60 Hz	50/60 Hz	50/60 Hz	50/60 Hz
Power consumption	700/1200W	700/1200W	1950/1200W	1950/1200W
Degree of protection	IP20	IP20	IP20	IP20
Overvoltage category	II	II	II	II
Pollution degree	2	2	2	2
Paper thimbles (Cellulose)	25 x 100 mm, 33 x 94 mm			
Solvents	Hexane, Chloroform, Petroleum ether, Diethyl ether			

Ambient conditions

For indoor use only, 5-40 °C, up to 2000 m above sea level, maximum relative humidity 80% for temperatures up to 31 °C decreasing linearly to 50% relative humidity at 40 °C.

Accessories

Glass parts	Qty	Order number	Picture
Condenser E-81x SOX and HE	1	047604	
Soxhlet glass chamber	1	047549	
Beaker, SOX	2	049427	
Beaker, SOX	12	045675	
Beaker, HE	2	049426	
Beaker, HE	12	045674	
Glass sample tube with frit	2	049430	
Glass sample tube with frit	12	11055738	

Additional parts	Qty	Order number	Picture
Z-seals, Viton	2	049431	
Seals, PTFE	6	049433	
Seal holder, PVDF	1	047610	
Valve unit complete	1	047590	
Membrane with anchor for valve unit	1	037534	
Expansion element, PTFE, for solvent volume reduction	1	051957	
Holders for glass sample tubes with frit	6	049432	
Thimble holder 25x100 mm	6	049428	
Thimble holder 33x94 mm	6	049429	
Pack of paper thimbles 25x100 mm	25	018105	
Pack of paper thimbles 33x94 mm	25	11058983	
Beaker holder (6 pos.)	1	047643	
Holder for glass sample tubes, PTFE, microwavable (6 pos.)	1	051903	
Holder for glass sample tubes, PP (4 pos.)	1	037462	
Chiller connection set E-812/816	1	11058415	
Distribution adapter for operating two extraction units with chiller	1	037742	
Condenser cover E-812	1	051198	
Condenser cover E-816	1	051822	
Quartz sand, 2.5 kg Special sand to be used for extraction and hydrolysis, fat free, fire dried, 0.3 - 0.9 mm	1	037689	

Documentation	Qty	Order number
IQ/OQ package for E-812/816 SOX	1	045657
IQ/OQ package for E-812/816 HE	1	045658
Repeating OQ for E-812/816 SOX	1	11055027
Repeating OQ for E-812/816 HE	1	11055028

Accessories pictures

Hot Extraction

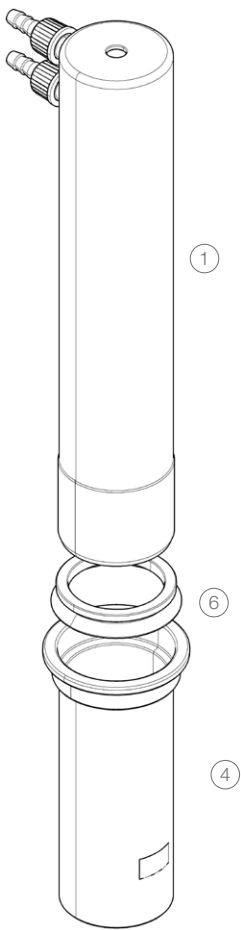

Soxhlet Extraction

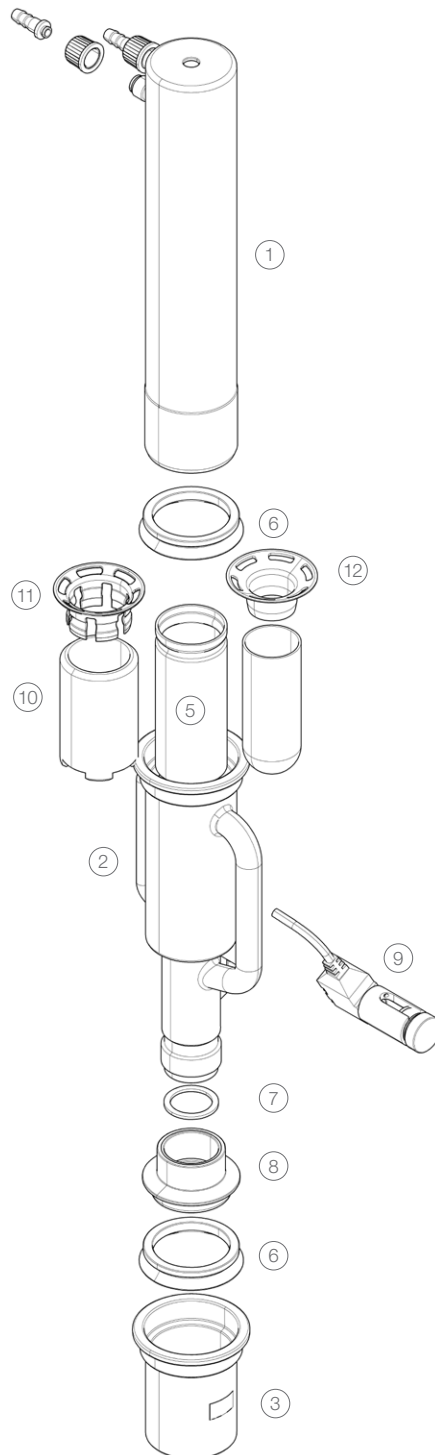

Functional principle

Soxhlet extraction

The Extraction Unit E-812/816 Soxhlet is designed for the fast and gentle extraction of fat from food and feed samples. The Soxhlet extraction process consists of 3 steps described in the following.

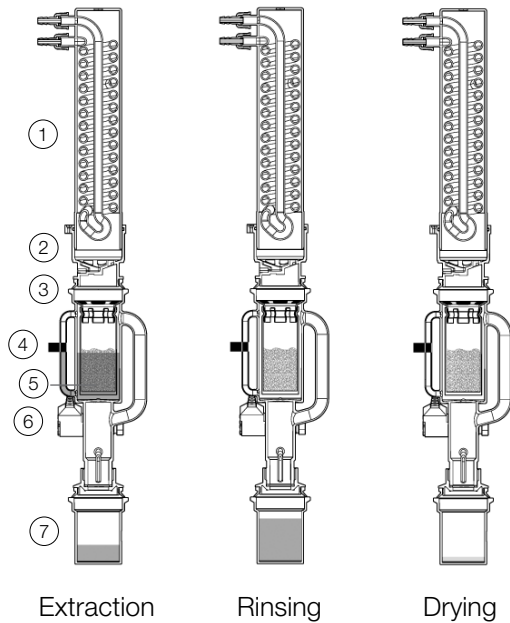

Extraction: The sample is extracted over a defined time period and/or cycles.

The solvent evaporates and the vapor rises up to the condenser (1). From there the condensed solvent flows through the receiving funnel (2) onto the sample (5). The tank valve and the glass valve (6) are closed. The extraction chamber is continuously filled with solvent, thereby extracting the analyte from the sample. When the level of the optical sensor (4) is reached, the glass valve (6) is opened and the solvent containing the extract flows into the solvent beaker (7). When the programmed number of cycles is reached and /or if the extraction time is reached, the next step is initiated.

Rinse: Residual extracts are removed by a continuous rinse.

The glass valve (6) is opened and the condensed solvent flows into the extraction chamber (5) and subsequently back into the beaker (7). The sample is then washed with fresh solvent.

Drying: The solvent is evaporated

The solvent is evaporated, condensed, collected beneath the condenser (2) and then transferred (3) to the cooled solvent tank for reuse. The extract is slowly evaporated to dryness.

Hot extraction

The Extraction Unit E-812/816 HE is designed for rapid determination of fat from food and feed samples. The hot extraction process consists of 3 steps described in the following.

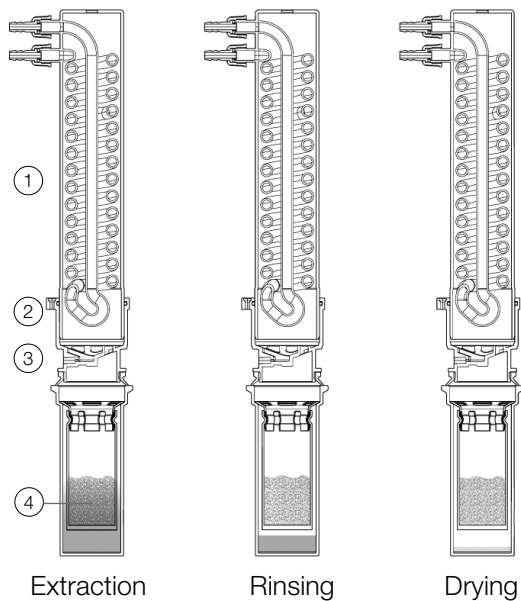

Extraction: The sample is extracted while dipped into the boiling solvent.

The solvent evaporates and the vapor rises up to the condenser (1). From there the condensed solvent flows back into the sample (4) through the receiving funnel (2). The tank valve is closed so the sample always remains in the boiling solvent. When the programmed extraction time is reached the next step follows.

Rinse: The sample is separated from the solvent and rinsed.

In order to remove residual extracts from the matrix, the sample is separated from the solvent, by reducing the solvent level through partial draining of the condensate to the tank (3). The draining is defined by time not volume. When the programmed rinse time is reached the system goes to the next step.

Drying: The solvent is completely drained to give the dry extract.

The solvent is evaporated, condensed, collected beneath the condenser (2) and transferred (3) to the cooled solvent tank for reuse. The extract is slowly dried whilst the solvent is removed.